

BOXER 522

ÇİFT DİYAFRAMLI HAVALI POMPA

Emme / basma hatları	G 2"
Hava giriş portu	G 1/2"
Max. kapasite	600 l/min
Max. basınç	8 bar
Max. basma yüksekliği	80 m
Max. katı partikül boyutu	8 mm
Ses seviyesi	80 dB



PVDF

BOXER 522

Maximum Ölçüler

Yükseklik	650 mm
Genişlik	590 mm
Derinlik	404 mm

Gövde Malzemesi (Şase ve Manifolrlar)

PVDF	45 Kg
	Max. 3°C min.
	95°C max

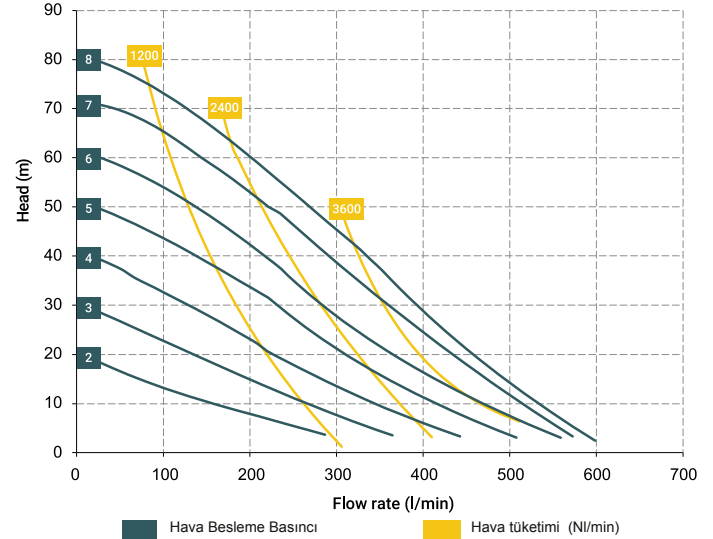

*The curves and the performances refer to pumps with immersed suction and open delivery outlet, with water at 20°C and vary based on the composition materials.

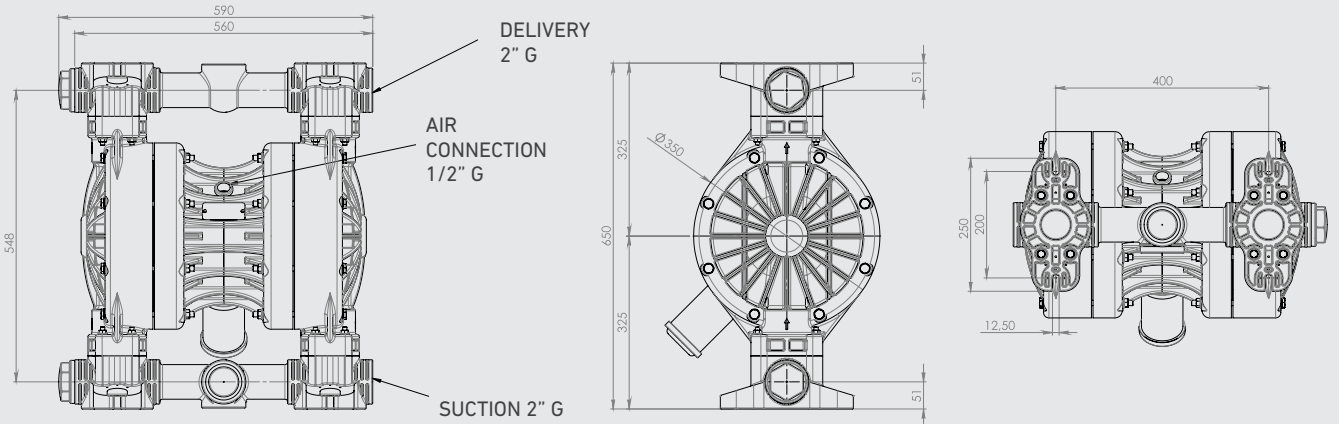

ANA UYGULAMA SEKTÖRLERİ



PRODUCTION AND STORAGE OF BIODEISEL



WATER AND SLUDGE TREATMENT



CHEMICAL INDUSTRY



OIL & GAS



CERAMIC, STONE, MARBLE GLASS AND MINING INDUSTRY



PAINT INDUSTRY



PACKING, GLUE, PAPER AND PAPER MILLS



TEXTILE AND LEATHER INDUSTRY



MECHANICAL AND METAL LURGIC INDUSTRY



GALVANIC AND ELECTRONIC INDUSTRY



